



UG1 Tungsten Electrode Sharpener & Grinder



OD Mounted





UG1 Tungsten Electrode Sharpener & Grinder

TUNGSTENE ELECTRODE: SHARPENING ; POINTING ; CUTTING MACHINE FOR TIG WELDING



GTAW (Gas tungsten arc welding), also called TIG (tungsten inert gas) welding, is an arc welding process that uses a non-consumable tungsten electrode to produce the weld. When it comes to GTAW/TIG welding, tungsten electrodes are the most important part of the application.

The tungsten electrode is the crucial carrier in the welding process and must be ground and cut properly. An improperly prepared electrode leads to arc wander, splitting, shedding and inconsistencies. Properly ground and cut electrodes improve drastically arc starting and stability.

OD Mounted

Advantages:

- Portable
- Light Weight
- Very Compact
- Repetitiveness of the Sharpening, pointing and Cut-Off
- High Precision
- Versatile
- Rugged
- Reliable
- Dry Sharpening, no coolant to change
- 220V, 110V Electric Drive

Dimensions:

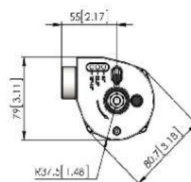
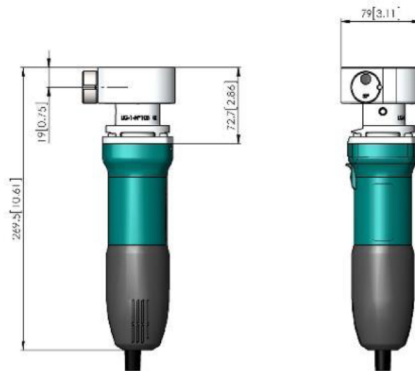



UG1 Tungsten Electrode Sharpener & Grinder

Technical Features:

Weight	1.9kg (4.19lb)
Motor	Electric 220V or 110V
Power	720W; 1HP; 3.2A
Motor Speed (unload)	40 000 rpm.
Feed	Manual
Electrodes Ø	1mm (0.04") 1.6mm (0.062") 2mm (0.08") 2.4mm (0.094") 3.2mm (0.125") 4mm (0.157")
Sharpening Angles	15°, 18°, 22.5°, 30°
Diamond Wheels	Diameter 50mm (1.97")
Cable	2m (6.5ft)
Noise Level	83db

Scope of Delivery:

Order Nr.	Description
UG-1-1020	Electrode grinder with 220V electric drive
UG-1-1040	Electrode grinder with 110V electric drive
UG-1-K01	Transport Case

Options:

Order Nr.	Description
UG-1-1115	Diamond wheel
UG-1-1123	Device to plug a vacuum cleaner
UG-1-1212	Machine Bench
UG-1-1300	Pencil
UG-1-1310	Sub-assembly electrode holder
UG-1-13C01	Clamping Collet - 1 mm diameter
UG-1-13C02	Clamping Collet - 1.6 mm diameter
UG-1-13C03	Clamping Collet - 2 mm diameter
UG-1-13C04	Clamping Collet - 2.4 mm diameter
UG-1-13C05	Clamping Collet -3.2 mm diameter
UG-1-13C06	Clamping Collet - 4 mm diameter
UG-1-1510	Collet-30°
UG-1-1511	Collet-15°
UG-1-1512	Collet-22.5°
UG-1-1513	Collet-18°

OD Mounted



Diamond Wheel



Device to plug a vacuum cleaner



Machine Bench



Collet



Clamping Collet

